

## Numerical Simulation of Gas Flow inside the Orbit Valve Class 900 and Its Effects on Parts Damages

Ali Reza Tahavvor<sup>1</sup>, Mohammadsadegh Korooni<sup>2</sup>

### 1. Introduction

Natural gas has been used as fuel for more than a century. Producing and distributing natural gas are among the most important economic sectors of some countries such as Iran. Several methods have also been developed to produce, purify, and refine gas. Water vapor is one of the impurities common to most natural gas sources that causes many problems in natural gas processing and transportation operations. Desalination is a process used to remove water vapor from gas. Its main purpose is to prevent the formation of hydrates and water condensation in process facilities and transmission lines and ultimately to prevent corrosion. One of the new methods of desalination of natural gas is surface adsorption. The quality of the outlet gas from the desalination unit depends on the dew point of the gas passing through desalination beds. In this process, four Class 900 ball valves are used. In this study, a Class 900 orbit valve is considered and the gas flow is simulated through it. The forces acting on the valve parts at different ball angles are determined. The internal mechanism is then analyzed by force when the maximum force is applied to the ball. The results can be used in designing similar valves and selecting suitable alloys for its components.

### 2. Numerical model

All valve components including the body, stem, inner parts, and actuator are designed according to figures 1 and 2. To simulate the flow of fluid passing through the valve, the ball valve inside the body is adjusted at angles of 15, 30, 45, 60, 75, and 90 degrees. To achieve a fully developed flow, the inlet and outlet pipe of the valve is 10 times of the valve inlet diameter.



Fig. 1. Internal components of the class 900 orbit valve

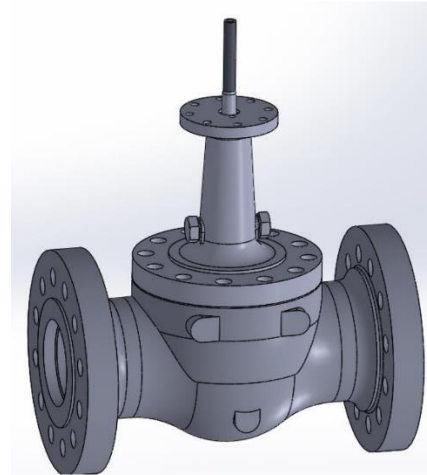

Fig. 2. Assembled model of the the class 900 orbit valve

Due to the 3D nature of the problem hexagonal grid elements for inlet and outlet parts and tetrahedral grid elements for the inner parts due to the complexity of their shapes are used. Boundary conditions are considered as follows:

Table 1. Boundary conditions

Operating fluid	Natural gas
Inlet pressure (bar)	89
Outlet pressure (bar)	87
Inlet temperature (C)	300

Some references show that RNG k- $\epsilon$  turbulence model is suitable for simulations in orbit valves. So, in this study, RNG k- $\epsilon$  model is used as a turbulence model.

### 3. Results

The velocity distribution of the gas passing through the valve at 15° is shown in Figure 3. According to the figure, the maximum velocity of flow passes through the space created between the seat and the sealing surface of the ball. In this case, the maximum speed is about 24 m/s.

<sup>1</sup> Corresponding Author: Associate Professor, Department of Mechanical Engineering, Faculty of Engineering, Shiraz Branch, Islamic Azad University, Shiraz, Iran, tahavvor@iaushiraz.ac.ir

<sup>2</sup> MSc Graduate, Department of Mechanical Engineering, Faculty of Engineering, Shiraz Branch, Islamic Azad University, Shiraz, Iran.

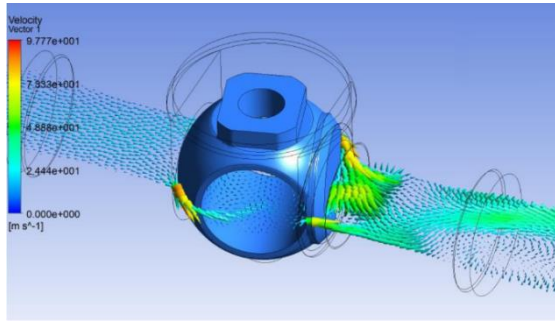

Fig. 3. Velocity distribution of flow through valve at 15°

Figure 4 shows the pressure distribution at an angle of 15 degrees. As the flow passes through the space between the seat and the hub, the pressure decreases as the speed increases. This low-pressure region exists until the inner diameter of the valve is changed.

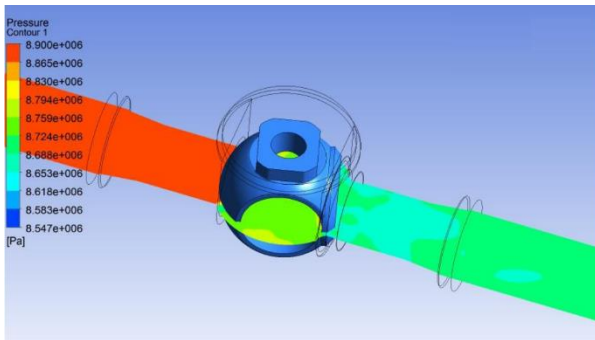

Fig. 4. Pressure distribution of flow through valve at 15°

The force components applied to the ball of the valve at different angles are shown in Figure 5. As the figure shows, the force in the flow direction increases with increasing value ball angle and reaches its maximum value at 45°. The force perpendicular to the flow also increased with the valve ball angle, reaching a maximum at 60°.

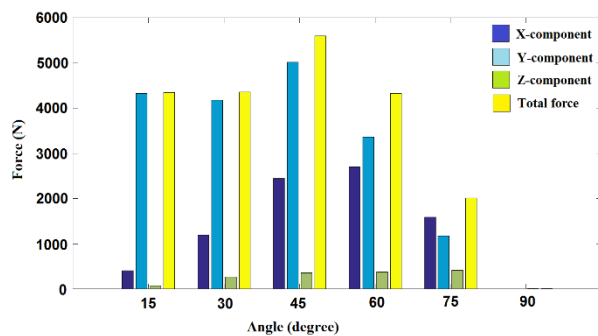

Fig. 5. Force components exerted to the valve

#### 4. Conclusion

The results of the simulation of the gas flow inside the orbit valve show that the difference between the inlet and outlet pressure causes the forces to be pushed into the hub and thus into the mechanism.

- The force exerted to the ball in the flow direction reaches its maximum value at 45°.
- The force exerted to the ball perpendicular to the flow direction reaches its maximum value at 60°.
- The total force exerted to the ball reaches its maximum value at 45°.